

MATERIALS

Roof: 8mm translucent polycarbonate PCSS
Structure: heavy gauge steel framing
Hardware: 5/8" x 4" embed stainless steel wedge anchor bolt (4 per column)
 1/2" thick stainless steel anchor plate, grade 309 alloy

FINISH

Galvanized

A hot dipped galvanized finish is our standard option and is protective against rust, corrosion and oxidation

Stainless Steel

Stainless steel does not stain, rust, or corrode as easily as ordinary steel

MOUNTING

Surface Mount

Mount in concrete foundation only with concrete anchors.
 3000 PSI concrete

Below Ground Mount

Anchor kits are available for an in-ground mounted Parachute shelter

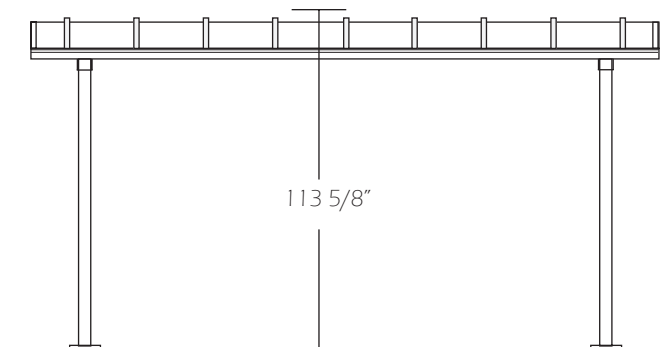
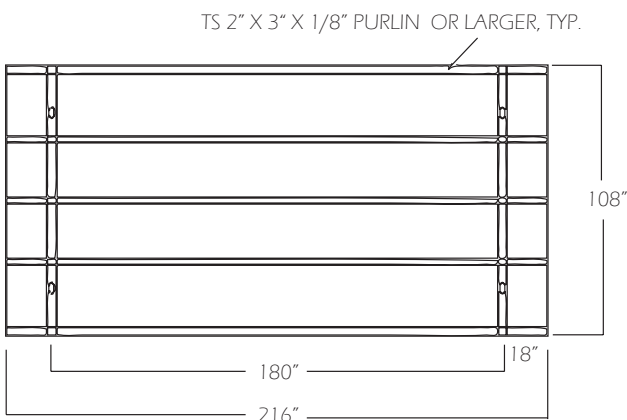

MINIMAL SPACE USE RECOMMENDATION

Setbacks depend on the specific style of Parachute Shelter you purchase, please see the manual that ships with your rack for specifications on space requirements.

Parachute Model Standard Sizes:

- 6' x 8' 8' x 18' 9' x 18'
- 8' x 8' 8' x 24' 9' x 24'
- 8' x 12' 9' x 12' 9' x 30'

**Custom Sizes Available*

*** Please contact Parkabike for questions or for specs on other Oasis outdoor shelters.*