

300 Series Bike Lockers

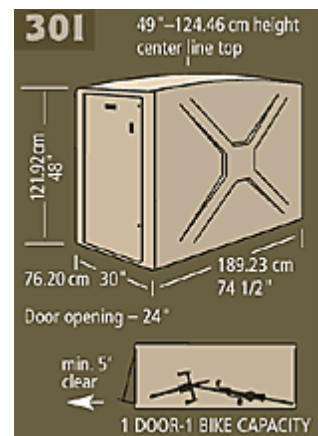

Specify the 300 Series lockers for the highest customer satisfaction from the no-assembly ready-to-use delivery through years of trouble free operation. Architects, designers and government agencies specify the 300 Series due to the high quality unitized manufacturing which means virtually no installation costs!

- NEW design, one piece FRP Composite bike locker- NO ASSEMBLY required.
- The 300 series is the first one piece locker available that is not molded of soft and flammable HDPE plastic material.
- Designed after our very popular 350 series of lockers and is available in 6 styles providing flexibility for site locations.
- All lockers are shipped assembled and can be stand alone or grouped—NO COMMON WALLS. Lockers easily relocated.
- High security with standard key locks recessed in door face and internal locking.
- The construction of fiberglass reinforced plastic is highly resistant to impact, stains and will not corrode.
- For those wanting more storage or room for 2-3 bikes in one locker we offer the Model #301W, same width as our two door versions but has door on one end only.

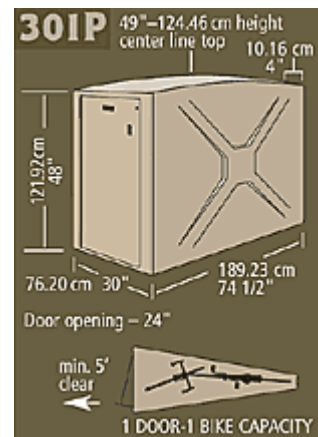
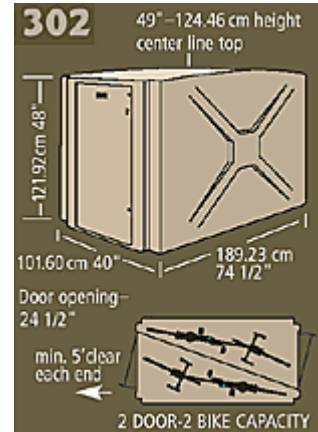

300 Series Bike Lockers

Optional Features:

- Fiberglass composite floors are ideal for storage lockers or if lockers cannot be anchored.
- Electronic Locking Systems: iButton or card reader.
- Heavy duty stainless steel pad lock handle will accommodate high security pad locks.
- Coin or Token operated locks for collection or money return.
- MEDECO™ stainless steel handle with T-Handle.
- Ventilation System: Stainless steel vents on doors for dissipation of heat and dampness.
- Safety-View windows and walls to check contents of lockers. Acrylic or expanded metal.

Standard colors or let us match your color

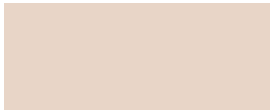

Tan



Medium Gray



Air Flow Grill

Lockers can be supplied with air venting grills to reduce the occurrence of mold and mildew.



Master Keyed Lock

7 pin tumbler Pop Out "T" handle locks with three keys and removable lock cylinders



Padlock Handle

Heavy duty padlock system that will accommodate high security padlocks (padlock not included) No Extra Charge



Coin Operated

Coin and token operated lock for collection or return



Medeco Lock

Medeco stainless steel high security T-Handle lock