

Pocket Shelter - Installation

Tools Needed for Installation:

Hammer
 Rubber Mallet
 Drill (Hammer drill recommended)
 3/8" masonry drill bit
 9/16" wrench/socket (2)
 Rivet tool for 1/4" rivets
 Folding ladder (2)
 2-3 people

Recommended Base Materials:

A concrete base is the best for surface installation. For installation into asphalt, separate anchors and instructions are needed.

Installation:

1. On a flat surface, place the Roof on its rear edge and lean it against a large object so its top is about 80 degrees to the ground.
2. Use the 1" carriage bolts to secure the Uprights to the Roof. If you are assembling several shelters in a series with Side Panels, note that the two exterior Uprights have small holes in them for rivets.
3. Grabbing the shelter by the rear edge of the roof, lift the shelter so it rotates about its rear feet until the shelter is upright and standing on all four feet.
4. Using the 2.75" bolts, secure the four Back Braces to the Uprights. Do not tighten the bolts. Note the placement of the Back Brace with no holes at second from the bottom if you're building a shelter with rear panels.
5. Place the two Bars on a flat surface parallel to each other and about 13.5" apart. Place a Bar Clamp on the end of each Bar. The .5" set bolt should be finger tight.

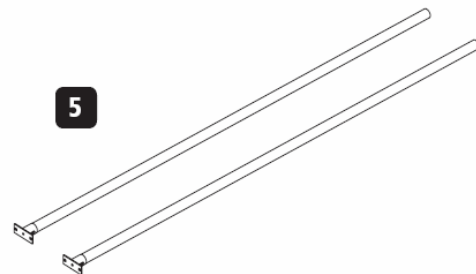
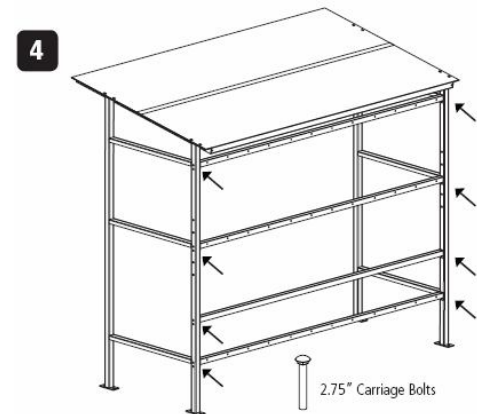
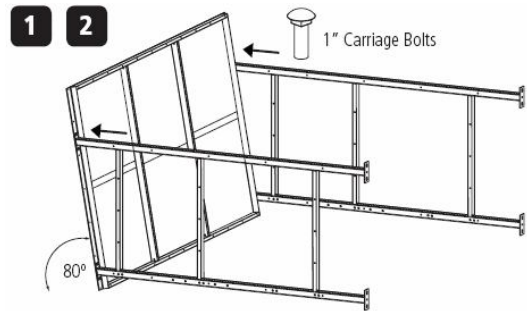

Pocket Shelter - Installation

6. Slide a 3" Spacer onto both Bars. Slide a Space Saver Ultra Arm onto both Bars using the upper and middle sleeve of the Arm.
7. Slide a 13" Spacer onto both Bars. This time, slide an Arm onto both Bars using the middle and lower sleeves.
8. Slide on the rest of the Arms and 13" Spacers so the Arms alternate up and down.
9. After the last Arm, slide on the 10" Spacers followed by the Bar Clamps. The set bolts should be finger tight.
10. Holding the upper Bar, lift the assembly into place and secure it to the uprights with the 2.75" bolts. Leave the Bar Clamp set bolts finger tight.
11. If you're using Rear Panels, rivet the Rear Panels to the Back Braces with a .5" Spacer between the Panels and Back Brace. Start with a Rear Panel on the right or left of the back of the shelter. The first rivet should be in the top row of holes towards the center of the Panel. The second rivet should be in the second row below the first rivet, and the third rivet should be in the third row below the first two rivets. Finish riveting the Panel to the Back Braces.
12. Repeat step 11 for the other two Rear Panels.

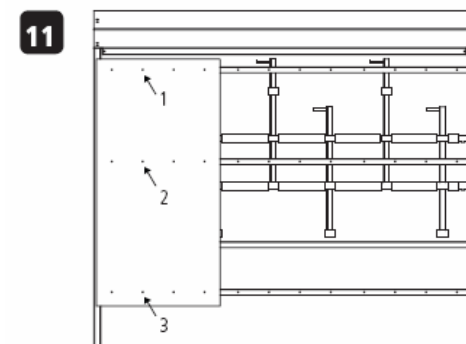
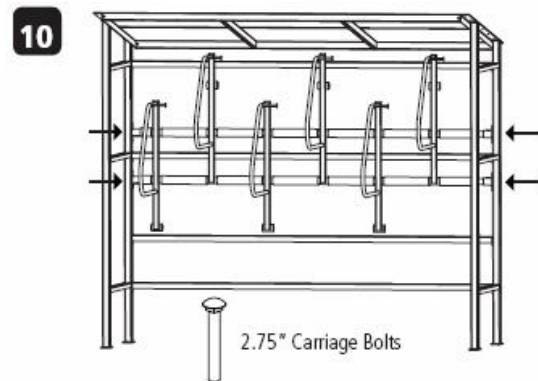
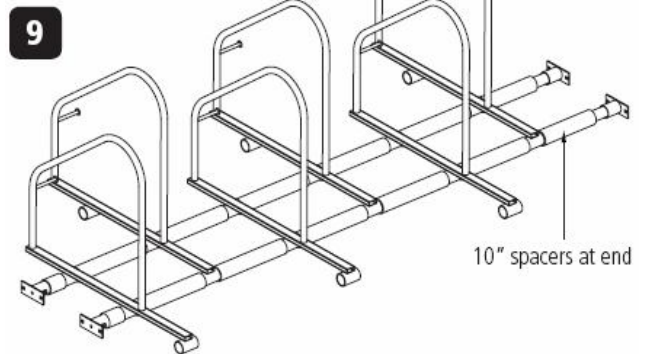
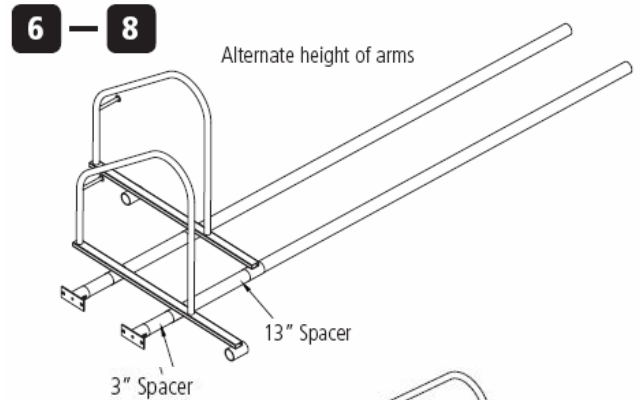

Pocket Shelter - Installation

13. Tighten all Bar Clamp set bolts.
14. Rivet the side panels to the Uprights as described in step 11. If you're building a series of shelters, do not add a side panel to the side where the next shelter will be added.
15. Move the shelter to its final location and drill 3" deep holes in the ground using the Upright feet holes as guides. Insert anchors and tighten.

14

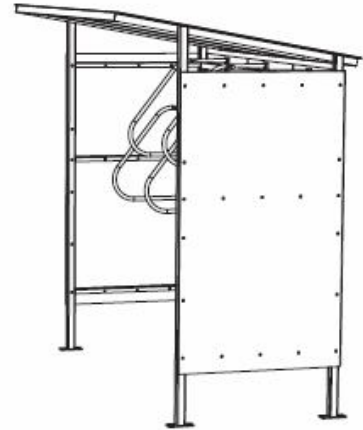

15

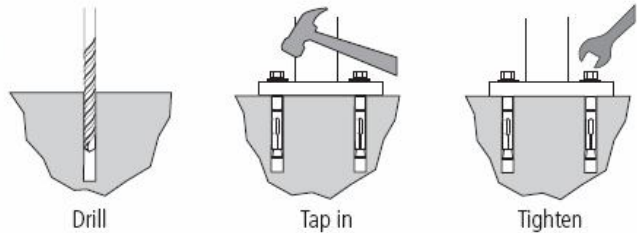

Footing Detail:

