

Ski Storage Rack Model #SR-2

1

Positioning Your Rack For Installation

Locate Studs. This rack has been designed to be installed into studs 16" on center with provided wood screws.

Determine height by taking your longest pair of skis, placing them into rack while holding rack against wall so that the toe piece of the binding is supported by lowest shelf, making sure that skis clear the floor.

Remove skis while holding rack in place, make sure rack is level and mark screw holes on wall through front of channel.

Remove rack from wall and drill 1/8" diameter pilot holes into studs. Align rack with screw holes and fasten to wall.

After rack has been securely fastened, snap hole plugs into place.

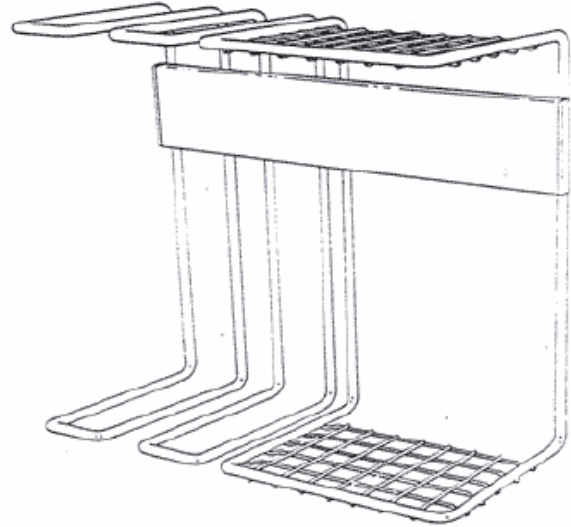

2a Hollow Wall Application

If only one or no studs are located, then use the provided mounting toggle(s).

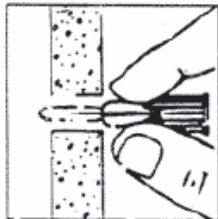

1 Drill 5/16" hole, squeeze toggle wings flat and push into hole.

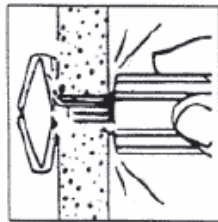

2 Tap flush with wall.

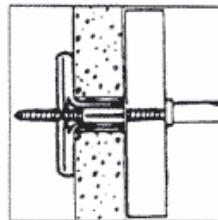

3 Put rack in place, insert screw(s) and tighten until secure.

2b Solid Wall Application

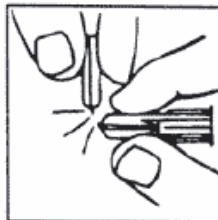

1 Squeeze toggle wings flat. Grasp at both ends and bend at middle joint until tip breaks off.

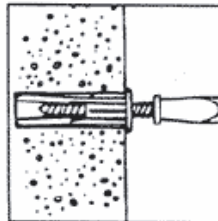

2 Drill 5/16" hole slightly deeper than remaining toggle length. Insert and tap flush with wall. Put rack in place, insert screws and tighten until secure.

3 Storing Your Equipment

This rack is designed to hold (2) pair each skis, poles and boots. Skis are hung by the binding toe piece. Insert skis thru the wider slots at each end of rack so the toe piece is supported by the lower shelf. Poles are stored in the narrower slot in the center by placing handle grips above upper shelf.